

## 2006-2009 Explorer

### Step: 1

Using a non marring tool unsnap the transmission selector trim bezel

### Step: 2

Remove two 7mm screws in center console finish panel and remove panel.

### Step: 3

Unsnap the center trim panel around radio and pull radio forward, then disconnect all connectors behind unit.

### Step: 4

Remove radio by unscrewing four 7mm bolts. (See figure A)

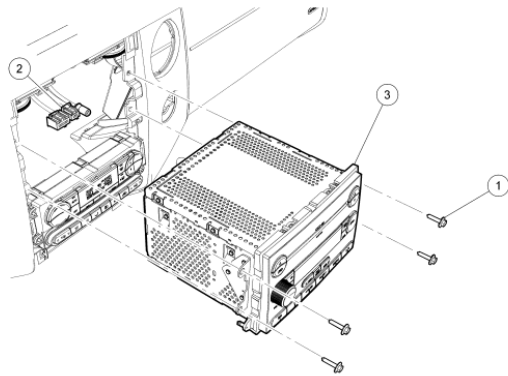

**Figure A**

### Step: 5

Disconnect 24 Pin Main Radio Connector and connect supplied 24 pin T-harness.

### Step: 6

Route the harness across dash through passenger side behind glove box and up A-pillar.

\* note if installing behind sun visor route cable up driver side

### Step: 7

Remove the A-pillar trim by first removing the assist handle covers and remove the two bolts holding the handle to the body. (See Figure B)

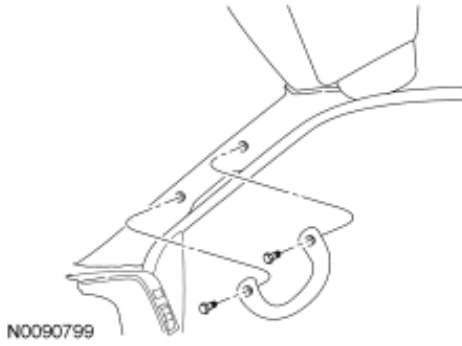

**Figure B**

**Step: 8**

Remove the A-pillar trim bezel by pulling on the upper part of the trim bezel toward the center of the vehicle.

**Figure: 9**

Route Harness to opening cut in headliner and connect to Bluetooth unit.

**Step: 10**

Reassemble A-pillar/ Radio and Dash bezel (note Assist Handle requires torque of 89lb per inch)