

## 2006-2009 Milan

### Step: 1

Using a non marring tool unsnap the trim bezel around radio cavity.

### Step: 2

Remove four 7mm screws holding radio in place. (see figure A)

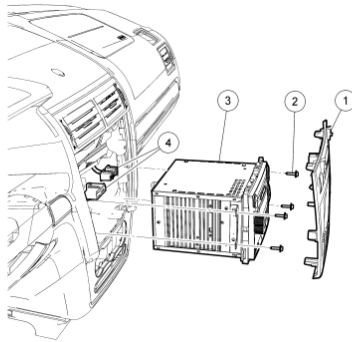

N0044460

**Figure A**

### Step: 3

Disconnect the 24 Pin Main Radio Connector and connect supplied 24 pin T-harness.

### Step: 4

Route the harness across dash through passenger side behind glove box and up A-pillar.

\* note if installing behind sun visor route cable up driver side

### Step: 5

Route the cable behind the door molding making sure not to cross the side curtain bag if equipped. **The dealer recommends using a new A-pillar trim clip used (not provided) if the A-pillar is removed.** (To remove the A-pillar simply rock the A-pillar gently from side to side to break clip loose).

### Step: 6

Route Harness to opening cut in headliner and connect to Bluetooth unit.

### Step: 7

Reassemble A-pillar molding/ Radio and Dash bezel.