

## 2007-2009 MKX

### Step: 1

Using a non marring tool unsnap trim bezel around the transmission selector lever. (See figure A)

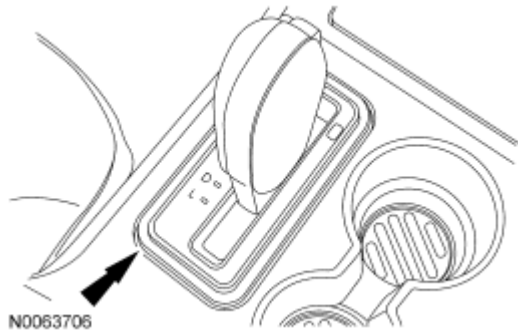

**Figure A**

### Step: 2

Using a non marring tool unsnap center console finish panel (unit containing the cup holders see figure A)

### Step: 3

Remove two 7mm screws holding the lower instrument panel storage compartment and remove the lower instrument panel storage compartment.

### Step: 4

Unsnap the bezel surrounding the radio and disconnect connectors behind the unit in order to remove bezel completely (note upper cover will be removed along with unit).

### Step: 5

Using a 7mm socket unscrew four screws holding radio and pull radio forward. (See figure B)

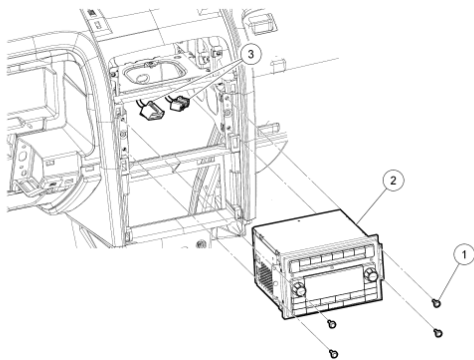

**Figure B**

**Step: 6**

Disconnect 24 Pin Main Radio Connector and connect supplied 24 pin T-harness.

**Step: 7**

Route the harness across dash through passenger side and up A-pillar.

\* note if installing behind sun visor route cable up driver side

**Step: 8**

Remove the A-pillar trim bezel by pulling on the upper part of the trim bezel toward the center of the vehicle. Once the bezel is loose remove the tether holding the bezel to the A-pillar insuring not to damage the tether. ( If tether is damaged during removal and or installation a new tether must be used in order to assure proper operation of side curtain airbag system). (See figure C)



**Figure C**

**Step: 9**

Route the harness up the A-pillar insuring **not to cross in front of the side curtain airbag. The harness should run between the metal from the A-pillar and the air bag NOT between the airbag and the trim bezel.**

**Step: 10**

Route Harness to opening cut in headliner and connect to Bluetooth unit.

**Step: 11**

Reassemble and reconnect A-pillar/ Radio and Dash bezel pieces.