

2008-2009 Mariner

Step: 1

Using a non marring tool unsnap trim bezel around the center upper A/C registers (around clock display)

Step: 2

Using a non marring tool unsnap the lower center console finish panel (unit containing the AUX jack input)

Step: 3

Remove four 7mm screws holding the center instrument panel trim around radio and unsnap making sure to disconnect all connectors attached to bezel.

Step: 4

Using a 7mm socket unscrew four screws holding radio and pull radio forward. (See figure A)

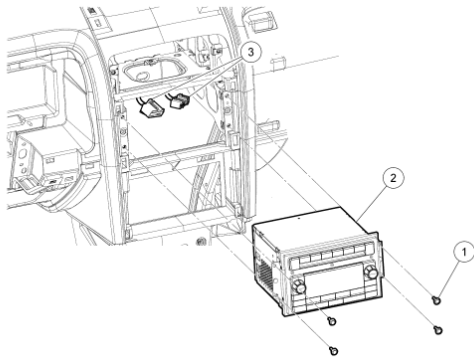

N0060099

Figure A

Step: 5

Disconnect 24 Pin Main Radio Connector and connect supplied 24 pin T-harness.

Step: 6

Route the harness across dash through passenger side behind glove box and up A-pillar.

* note if installing behind sun visor route cable up driver side

Step: 7

Remove the A-pillar trim by first removing the assist handle covers and remove the two bolts holding the handle to the body. (See Figure B)

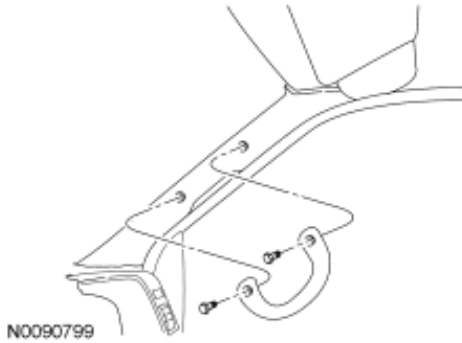

Figure B

Step: 8

Remove the A-pillar trim bezel by pulling on the upper part of the trim bezel toward the center of the vehicle. Once the bezel is loose remove the tether holding the bezel to the A-pillar insuring not to damage the tether. (If tether is damaged during removal and or installation a new tether must be used in order to assure proper operation of side curtain airbag system). (See figure C)



Figure C

Step: 9

Route Harness to opening cut in headliner and connect to Bluetooth unit.

Step: 10

Reassemble A-pillar/ Radio and Dash bezel