

2008-2009 Super Duty

Step: 1

Using a non marring tool unsnap the Aux input cover and the matching cover on opposite side.

Step: 2

Remove two 7mm screws in behind covers.

Step: 3

Unsnap the center trim panel around radio and pull radio forward, then disconnect all connectors behind unit.

Step: 4

Remove radio by unscrewing four 7mm bolts. (See figure A)

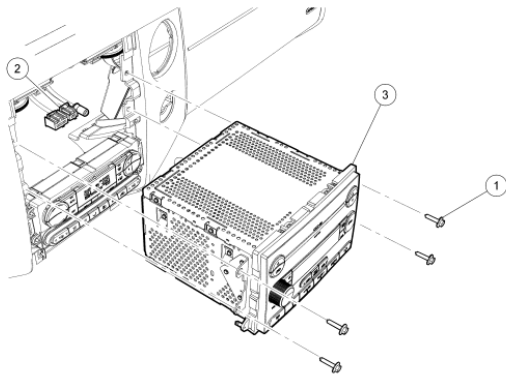

N0057178

Figure A

Step: 5

Disconnect 24 Pin Main Radio Connector and connect supplied 24 pin T-harness.

Step: 6

Route the harness across dash through passenger side behind glove box and up A-pillar.

* note if installing behind sun visor route cable up driver side

Step: 7

Remove the A-pillar trim by first removing the assist handle covers and remove the two bolts holding the handle to the body. (See Figure B)

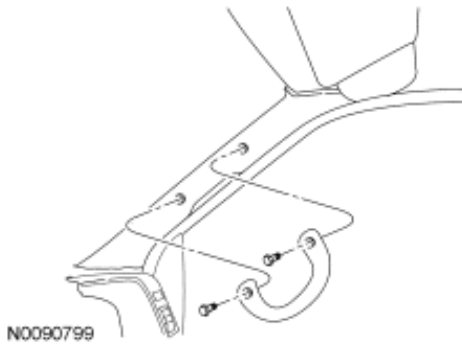

Figure B

Step: 8

Remove the A-pillar trim bezel by pulling on the upper part of the trim bezel toward the center of the vehicle.

Figure: 9

Route Harness to opening cut in headliner and connect to Bluetooth unit.

Step: 10

Reassemble A-pillar/ Radio and Dash bezel (note Assist Handle requires torque of 106lb per inch)