

Rear Vision System – Aftermarket Display 2007-Current Chevrolet Silverado, Silverado HD; GMC Sierra, Sierra HD (Kit part number 9002-9560)

Kit Contents:

- Chassis Harness with RCA (**Note: In some cases a RCA extension may be required to connect to your aftermarket display. Kit #6111 may be purchased at Brandmotion.com for these cases.**)
- 1 bubble bag containing:
 - Camera/Module/Tailgate Bezel Assembly
- 1 bag containing:
 - Lock Plug (optional)
- 1 bag containing:
 - Jumper Harness
- 1 bag containing:
 - Template (along with these instructions)

Tools Required:

- Socket Wrench
- 10mm and 13mm Sockets
- T15 and T20 Torx Bits
- Torque Wrench
- Trim Removal Tool
- Phillips and Flat Blade Screwdrivers
- Delphi Terminal Tool 12094429 or a small flat blade watch repair screwdriver
- Power Drill
- 25.4mm (1") Hole Saw
- 29mm (1-1/8") Hole Saw
- Deburring Tool
- Center Punch
- Electrical Tape
- Vehicle Hoist
- Wire Ties (recommended)
- Corrosion Inhibitor (recommended)



Note: We strive to provide accurate and up-to-date installation instructions. For the latest full color instructions, as well as an installation video, please visit www.brandmotion.com

IMPORTANT: Before beginning kit installation, verify kit contents are complete against list above.

INSTALLATION INSTRUCTIONS

Preparation

1. Ensure all lamps and accessories are OFF.
2. Ensure the ignition switch is in the OFF position.
3. Loosen the negative battery cable bolt. Remove negative battery cable from terminal and position away from battery.
4. Wait one (1) minute prior to working on the vehicle to assure SIR roof rail airbag system has been disabled for your safety.

Install Camera Bezel into Tailgate

5. Lower Tailgate and remove center bezel mounting bolt (1), using 13mm socket. Figure 1.

FIGURE 1

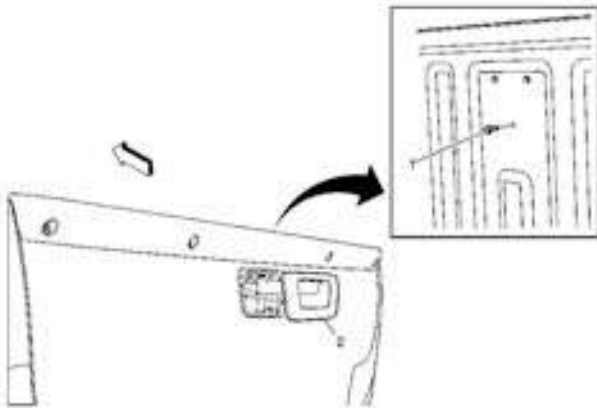

6. Release, by hand, the three retainer clips securing the bezel (2) to the Tailgate outer panel. Lift the Tailgate latch handle in order to aid in the removal of the latch handle bezel. Figure 1.
7. If the Truck is not equipped with Tailgate Lock (&A60), remove the two upper Tailgate Latch Handle Bolts (1) from the Tailgate Latch Handle (2), using 13mm socket. Figure 2. Release Rods before removing (inset). If equipped, skip this step.

FIGURE 2

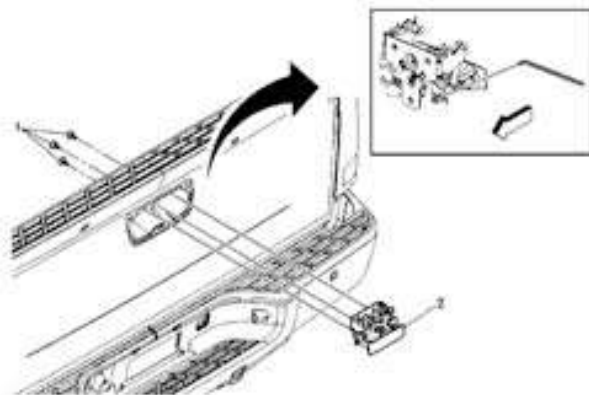

8. Prepare a work surface for the Tailgate, as it will be removed.
9. Disconnect the two Tailgate support cables. Figure 3.

FIGURE 3

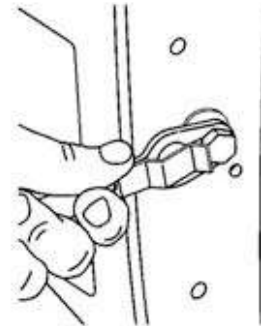

10. With the aid of an assistant, remove the Tailgate and locate to clean work surface. Figure 4.

FIGURE 4

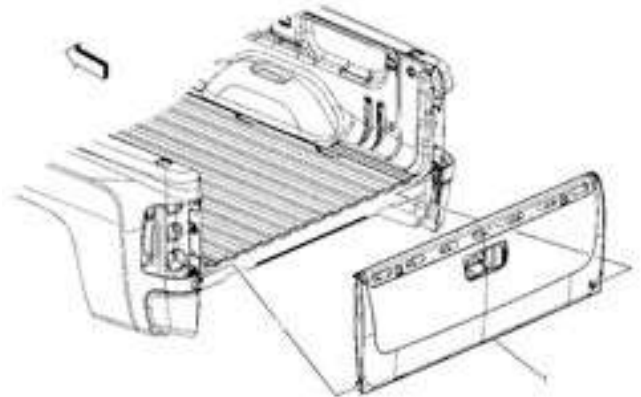

11. Locate the supplied Template Sheet for the Tailgate and Pickup Box Sill.

Note: For Model Year 2009 and forward, some vehicles may already have a flanged hole in the pickup box sill. If this is the case, remove the flange from the front side of the sill and skip Steps 13 & 15.
12. Cut out Tailgate Template and attach to Tailgate using tape. Using the Center Punch, mark the center of hole.
13. Cut out Sill Plate Template and attach to Pickup Box Sill using tape. Using the Center Punch, mark the center of hole.
14. Using a power drill and a 29mm (1-1/8") Hole Saw, cut out the harness pass-through in the Tailgate. Figure 5.

INSTALLATION INSTRUCTIONS

FIGURE 5

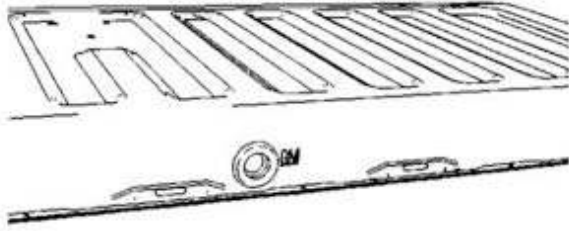

15. Using a power drill and a 29mm (1-1/8") Hole Saw, cut out the harness pass-through in the Pickup Box Sill. Figure 6.

FIGURE 6

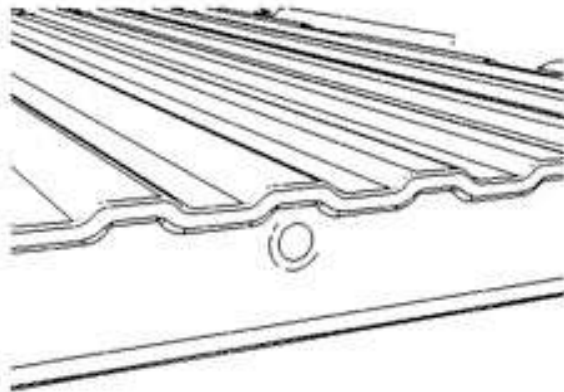

16. Clean rough edges using a deburring tool.
17. Apply Anti-Corrosion Coating to the two cut outs.
18. Locate the supplied Rear Vision Camera Bezel Assembly. Figure 7.

FIGURE 7



19. If the Truck is equipped with a factory Tailgate Lock, remove the lock cylinder from the original Tailgate Bezel. Remove the Tailgate Lock Cylinder Retaining

- Clip (1) and then the Tailgate Lock Cylinder (2). Figure 8.

FIGURE 8

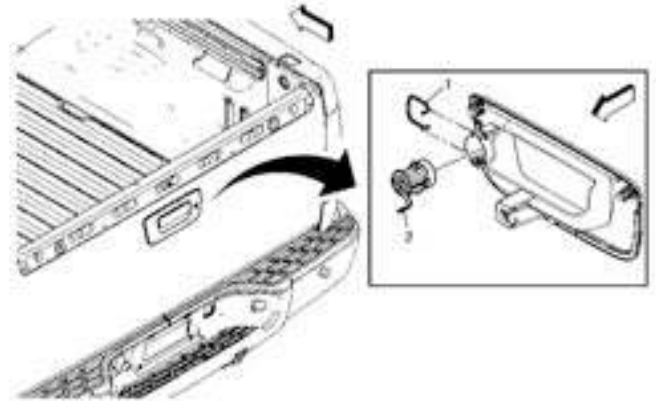

20. If equipped, insert the Tailgate Lock Cylinder (2) into the new Tailgate Bezel and re-attach the Tailgate Lock Cylinder Retaining Clip (1). Figure 8.
a. If the Truck is not equipped with factory Tailgate Lock, install supplied Lock Plug.
b. If locking features are desired, a Tailgate Latch Handle (part number 25775280) and a Tailgate Lock Cylinder (part number 25775278) are available through GM dealer.
21. Install the supplied Tailgate Bezel Assembly, first route the Camera Assembly harness pigtail through the Tailgate Bezel opening down through the Tailgate to the 29mm hole at the bottom of the Tailgate. Figure 9.

FIGURE 9

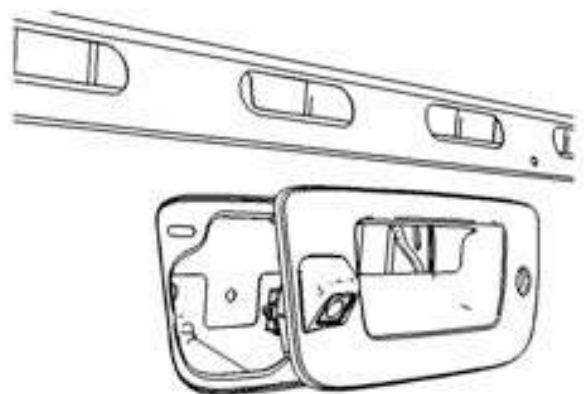

22. Pull connector (2), first grommet (3), and second grommet (4) through new Tailgate (1) pass-through. Figure 10.

FIGURE 10

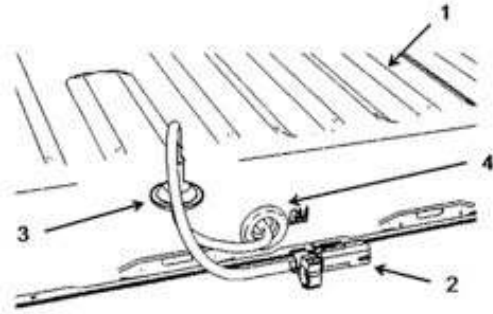

23. Snap the supplied Tailgate Bezel Assembly into the Tailgate.
24. Seat the second grommet (4) securely around opening. Figure 10.
25. Install remaining Tailgate Latch Handle Bolt in Tailgate and tighten all three 13mm bolts to 25 N·m (18 lb ft).
26. If present, remove the Rear License Plate.
27. With the help of an Assistant, re-install the Tailgate onto the Pickup Box, carefully routing the Camera harness through the opening on the Pickup Box Sill.
28. Re-attach Tailgate Support Cables and close Tailgate. Figure 11.

FIGURE 11

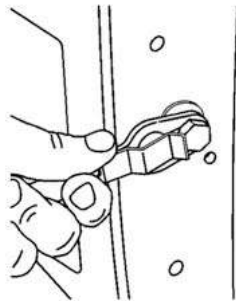

29. Through the License Plate Opening pull the Camera Assembly Harness (2) until the first grommet (3) is properly seated in the Pickup Box Sill (1). Figure 12.

FIGURE 12

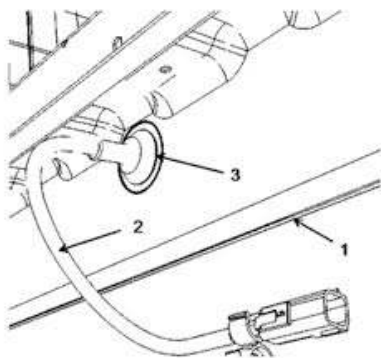

INSTALLATION INSTRUCTIONS

Determine Reverse Signal Location

30. Using a Trim Removal Tool, remove Left Instrument Panel Outer Trim Cover (1). Figure 13.

FIGURE 13

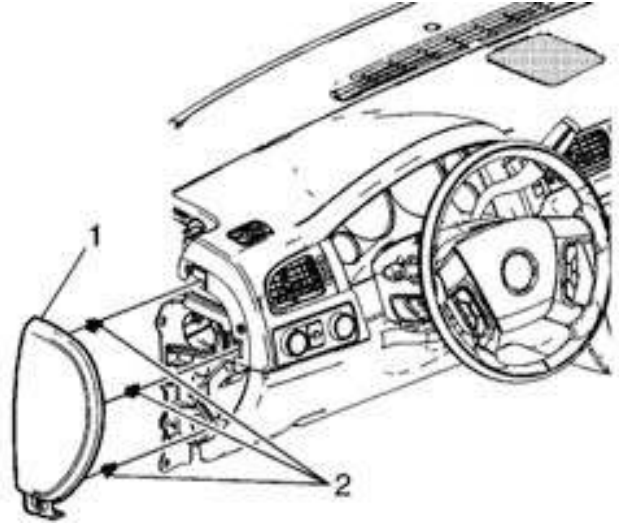

31. Remove M-BEC cover under the dashboard by popping it off with hands. Figure 14.

FIGURE 14



32. Have an assistant set parking brake, start vehicle, and shift into Reverse. Using a digital multimeter, check for Reverse signal in Cavity 5 at the Light Gray C11/X11 Connector **OR** Cavity 8 of Gray C10/X10 Connector in the M-BEC. Figures 15, 16, and 17.

INSTALLATION INSTRUCTIONS

FIGURE 15

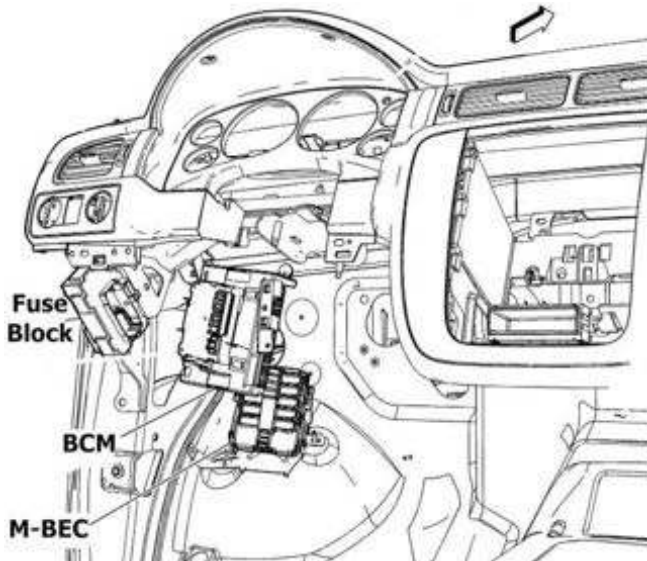

FIGURE 16

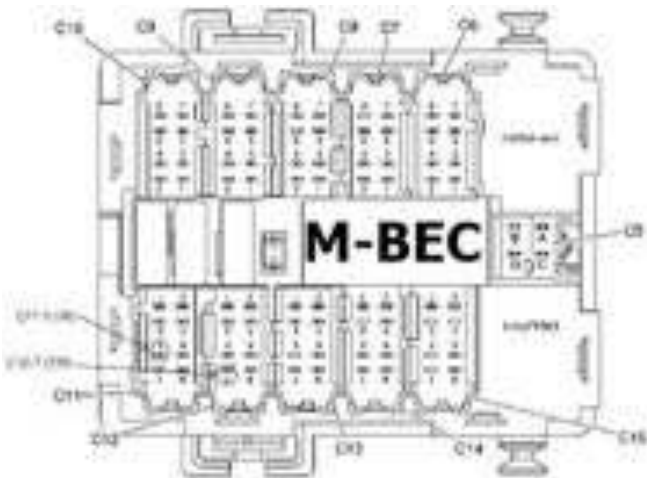
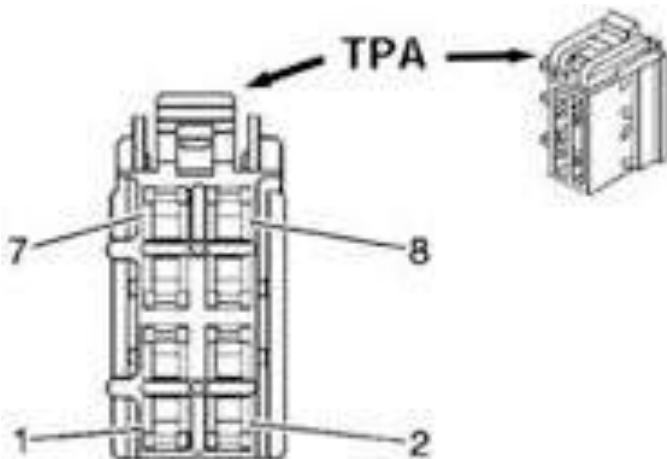

FIGURE 17



33. **If Reverse signal is NOT present** in the C10/ X10 Connector or C11/ X11 Connector:

- A. Check that bail that secures the M-BEC connectors is fully locked. Repeat Step 33.
- B. If Reverse signal is still not present, check Fuse Block for any blown fuses. Figure 15. Replace any blown fuses and repeat Step 33.
- C. **If Reverse signal is still NOT present**, connection to Reverse signal must be made at the BCM rather than the C10/ X10 or C11/ X11 Connector (refer to Step 50 under "Install Chassis Harness & Connect to Aftermarket/ NAV Display").

Cut Accessory Pass-Through in Front of Dash

34. Remove Parking Brake Release Handle Bolt and the Handle. Remove two Knee Bolster Assembly Screws (1) and Knee Bolster Assembly (2). Figure 18.

FIGURE 18

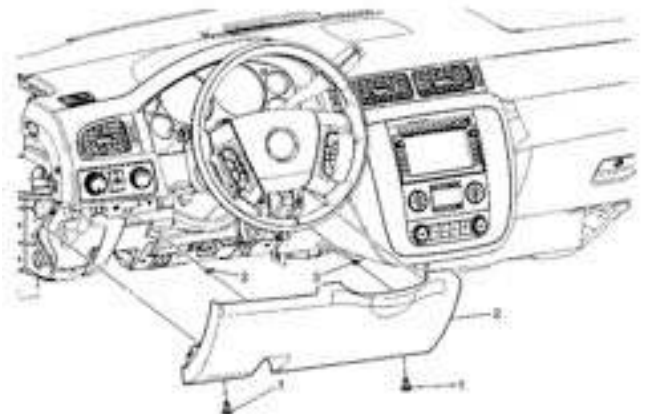

35. Disconnect the electrical connections, if applicable.
36. Disengage the M-BEC (1) from support bracket. Figure 19.

FIGURE 19

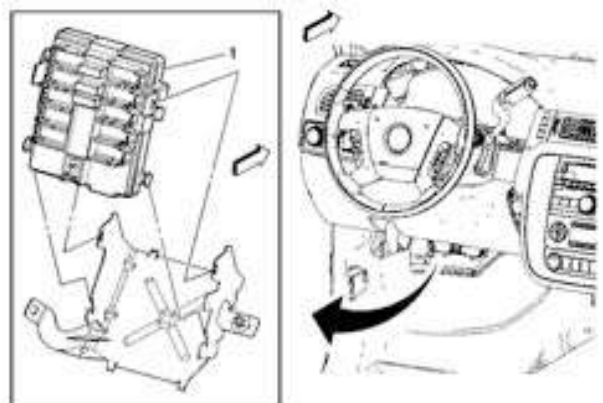

INSTALLATION INSTRUCTIONS

37. Relocate M-BEC up into the IP to gain access to Front of Dash Mat Opening behind M-BEC.
38. Locate cut-out in dash Mat. Locate the dimple in the sheet metal and then use a center punch to help start a drill bit as close as possible to dimple. Using a power drill and a 25.4mm (1") hole saw, drill out the chassis harness pass-through (2). Figure 20.

FIGURE 20

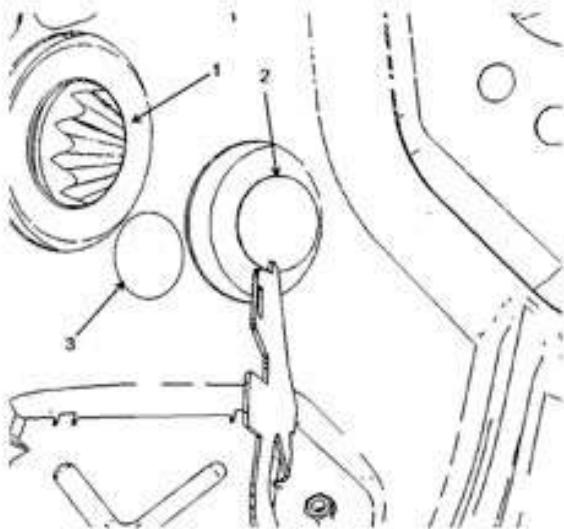

39. If this location is occupied by Trailer Brakes (&JL1) or another Accessory, drill a new Chassis Harness pass-through (3) between the IP Harness (1) and Trailer Brake (2) pass-through grommets. Figure 20.
40. Clean rough edges using a deburring tool. Figure 20.
41. Apply Anti-Corrosion Coating to the opening. Figure 20.

Install Chassis Harness & Connect to Aftermarket/ NAV Display

42. If needed, install aftermarket display/ Navigation display as per instructions.
43. Locate the supplied Rear Chassis Harness with RCA.
44. Route the grommet-end of the Chassis Harness through the Driver's Side Wheel Housing and then through the opening in the Front-of-Dash. Figure 21.

FIGURE 21

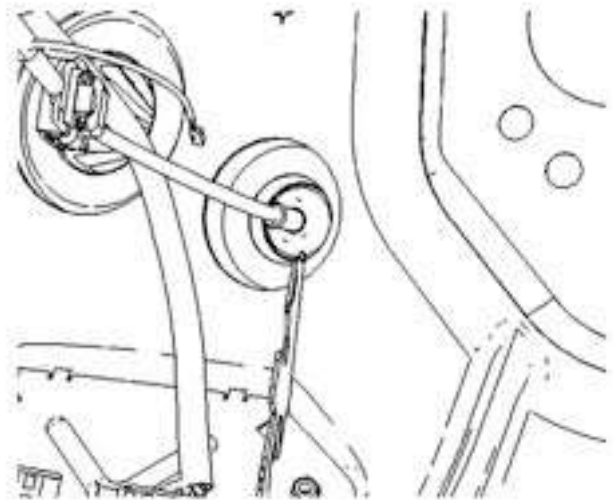

45. From the inside of the cab pull the Chassis Harness through until the grommet is properly seated.
46. Connect male RCA from supplied Chassis Harness to camera IN on the aftermarket display/ Navigation display. In some cases a RCA extension may be required.
47. If you located Reverse and Ignition signals in the M-BEC connector, connect the remainder of the leads from supplied Chassis Harness to vehicle wiring per Chart A and proceed to Step 50. Otherwise, skip to Step 49.

Chart A

Color	Polarity	Function	Connect to:
Green	+	Reverse	Splice to wire in M-BEC C11/ X11 light gray connector pin 5 OR M-BEC C10/ X10 gray connector pin 8
Red or Pink	+	Ignition	Splice to wire in M-BEC C12/ X12 brown connector pin 7
Black	-	Ground	Stud on left hand side of dashboard
RCA plug	AC	Video Out	Monitor

INSTALLATION INSTRUCTIONS

48. **If all M-BEC connections were secure and no fuses were blown and Reverse was still not present**, Reverse must be located in the under dash BCM left of the steering wheel. Figure 15
- A. Cut connector off green Reverse (+) wire of supplied Mirror Harness and splice to wire in Brown BCM X5 Connector Cavity 11. Figures 15 & 22.

FIGURE 22

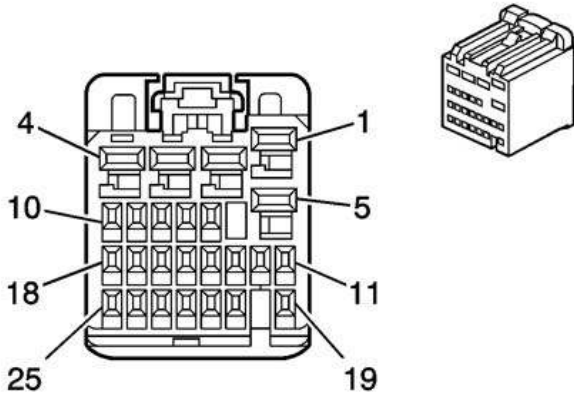

- B. Cut terminal off pink ignition (+) wire of supplied Mirror Harness and splice to wire in Brown BCM X5 Connector Cavity 13. Figures 15 & 22.
49. Install M-BEC into the Support Bracket. Figure 15.
50. Install the M-BEC cover onto the M-BEC.
51. Raise Truck up on a hoist to route the Chassis Harness.
52. Route supplied Chassis Harness, working towards rear of the vehicle, along the existing Chassis Harness, routing away from Body Mounts.
53. Connect Chassis Harness Connector (2) to Camera Assembly Harness Connector (1). Figure 23.

FIGURE 23



54. Secure the Rear Vision Camera Harness along the existing Chassis Harness using Wire Ties every 200mm (approx. 8"). Note: Depending on the vehicle wheelbase there may be excess length in the Rear Vision Camera Chassis Harness. Loop, and secure any excess harness length with wire ties along the Body Frame away from Mechanical areas.
55. Lower the truck.
56. Re-Install Rear License Plate, if necessary.

57. Connect the negative battery terminal. Tighten the negative cable nut to 5 N·m (44 lb in).
58. Test system functionality.
59. Re-install the Knee Bolster Assembly. Tighten Screws to 2 N·m (18 lb in). Re-install Parking Brake Release Handle and Bolt, tighten to 9 N·m (80 lb in). Figure 14.
60. Re-install Instrument Panel Outer Trim Cover. See Figure 13.

Camera and Chassis Harness Pinouts (REFERENCE ONLY)

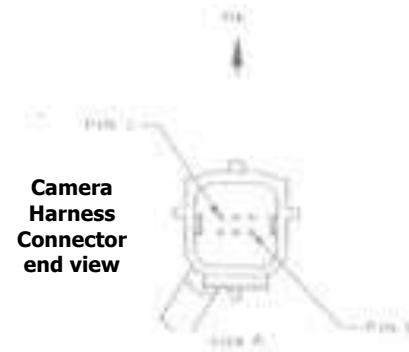

PIN #	FUNCTION	CAMERA HARNESS COLOR	CHASSIS HARNESS COLOR
1	Video +	Yellow	White
2	Shield	White	Blue
3	Reverse	Brown	Green
4	Video -	Gray	Brown
5	Ground	Black	Black
6	Ignition +	Red	Red